

2

1

**PROPRIETARY AND CONFIDENTIAL**

THE INFORMATION CONTAINED IN THIS DRAWING IS THE SOLE PROPERTY OF PRESSURELINKS. ANY REPRODUCTION IN PART OR AS A WHOLE WITHOUT THE WRITTEN PERMISSION FROM PRESSURLINKS IS PROHIBITED.

B

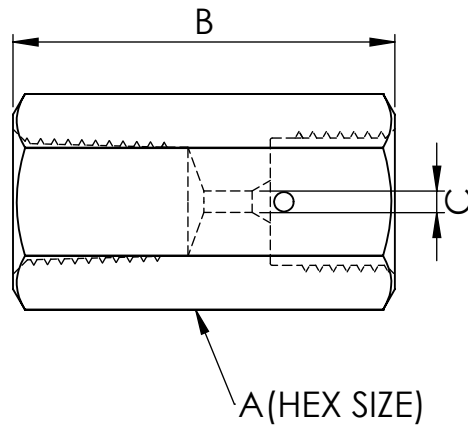

B

DESCRIPTION	PL PART #	(A) HEX	(B) OAL	(C) THRU $\phi$	WEIGHT(LBS)
1/4 NPT FEM X 1/4 HP FEM	4NF04HF15	0.750	1.53	0.086	.15
1/4 NPT FEM X 3/8 HP FEM	4NF06HF15	1.000	1.73	0.120	.32
1/4 NPT FEM X 9/16 HP FEM	4NF09HF15	1.375	1.90	0.182	.65
3/8 NPT FEM X 1/4 HP FEM	6NF04HF15	0.875	1.56	0.086	.20
3/8 NPT FEM X 3/8 HP FEM	6NF06HF15	1.000	1.75	0.120	.30
3/8 NPT FEM X 9/16 HP FEM	6NF09HF15	1.375	1.94	0.182	.64
1/2 NPT FEM X 1/4 HP FEM	8NF04HF15	1.125	1.79	0.086	.41
1/2 NPT FEM X 3/8 HP FEM	8NF06HF15	1.125	1.98	0.120	.42
1/2 NPT FEM X 9/16 HP FEM	8NF09HF15	1.375	2.16	0.182	.68
3/4 NPT FEM X 1/4 HP FEM	12NF04HF15	1.375	1.83	0.086	.63
3/4 NPT FEM X 3/8 HP FEM	12NF06HF15	1.375	2.01	0.120	.67
3/4 NPT FEM X 9/16 HP FEM	12NF09HF15	1.375	2.20	0.182	.62
1 NPT FEM X 1/4 HP FEM	16NF04HF15	1.750	2.06	0.086	1.15
1 NPT FEM X 3/8 HP FEM	16NF06HF15	1.750	2.26	0.120	1.26
1 NPT FEM X 9/16 HP FEM	16NF09HF15	1.750	2.44	0.182	1.25

A

A

**PressureLinks**  
High Performance Fittings

TITLE:

**110 NPT FEMALE X HP FEMALE  
MASTER LIBRARY**

SIZE

**A**

DWG. NO.

**NPT FEMALE X HP FEMALE**

REV

**A**

SCALE: 1:1

SHEET 1 OF 1

2

1